

Model 7037 Sterndrive Steering Cylinder



This cylinder is designed for the Mercruiser and Volvo sterndrives which incorporate the use of two pins to hold the cylinder in place. The cylinder has a 1 1/2" I.D. and a 6 1/2" stroke. It is constructed of corrosion resistant bronze, brass and stainless steel and will give you many years of dependable service. This cylinder will far outlast the competition and individual parts are available for future maintenance.

The bottom image shows the detail of the bore where the pin would secure the cylinder. Since Mercruiser and Volvo use different size pins, this bore can be sleeved to accept the smaller pin size. Please let us know which sterndrive you would be outfitting with this cylinder so that we can provide you the sleeves should you require them.

Dimensions and Parts

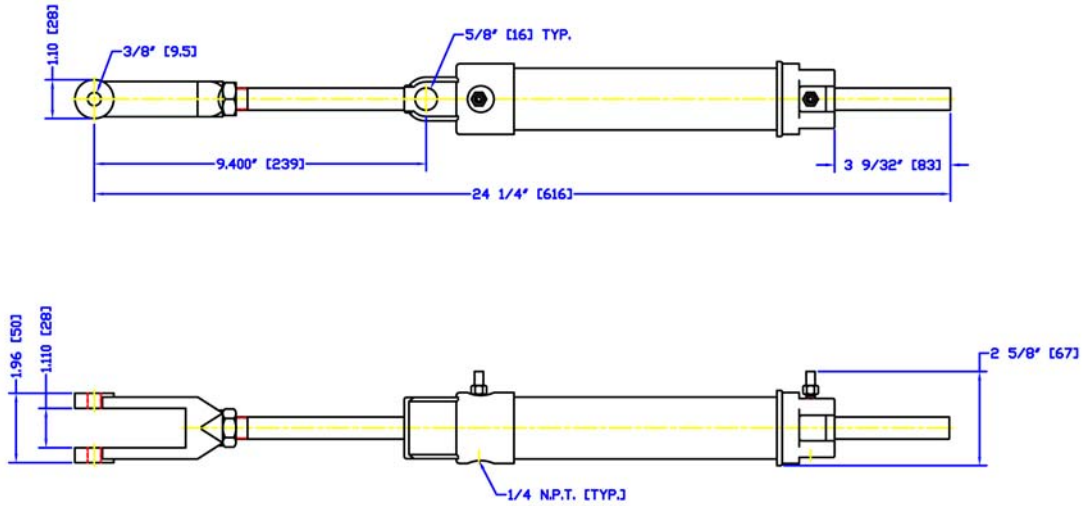

All dimensions are in inches (mm)

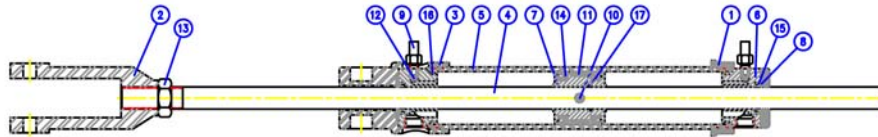

ITEM	QUANTITY	PART #	DESCRIPTION
1	1	7037-0001	End Cap
2	1	7037-0002	Clevis
3	1	7037-0003	End Cap
4	1	7037-0004	Piston Rod
5	1	7040-0006	Cylinder Tube
6	2	7040-0007	Rod Guide
7	1	7040-0008	Piston
8	2	7040-0010	Retaining Washer
9	2	7030-0011	Bleeder Screw
10	1	7040-0012	Pin
11	1	7040-0013	Wear Ring
12	2	1301-0005	Ball
13	1	1022-xxxx	Hex. Jam Nut
14	2	1102-2026	U-cup
15	2	1102-2006	U-cup
16	2	1101-0125	O-Ring
17	1	1101-0016	O-Ring