

Model 2093 Remote Control



Model 2093 remote control for model 2091 is of the same rugged design. Entirely made up of die cast silicon bronze and stainless steel hardware and is backed with our usual warranty. This head comes with all the hardware to mount the interconnecting cables. These must be 47 series pull/pull cables.

The cable is attached with the clamps on the bottom of the supports of the control heads and the chain can be placed over the sprocket. When the control head is in the neutral position (handle in mid-position), the loose ends of the chain should be of equal lengths on either side of the sprocket. The cable core is equipped with two nuts on either end. One of the nuts must be removed then the cable end can be passed through the adapter link. The nut can now be re-installed.

It is also important to remember that the cable must be crossed between the control heads in order to get the handles to move in the same direction. Note that the forward cable from the master station is attached on the aft side of the remote station and the forward cable of the remote station is attached to the aft side of the master station.

The cables have enough thread at the end to allow balancing of the handles at both stations. The best way of accomplishing this is by placing the master station in the neutral position (handle straight up). The adjusting nuts at the end of the cable can now be tightened or loosened as required to balance the handles. Note that over tightening of the cable core will result in excessive friction and will make the control system very stiff and difficult to operate.

A deflection of 3/8" to 1/2" in the cable to either side between the sprocket and the cable conduit clamp is essential. It is important that the two nuts at the cable end are secured tightly against the adapting link. To accomplish this you must use two 3/8" wrenches. Under no circumstances must the chain be twisted when tightening these nuts.

Dimensions and Parts

Side View

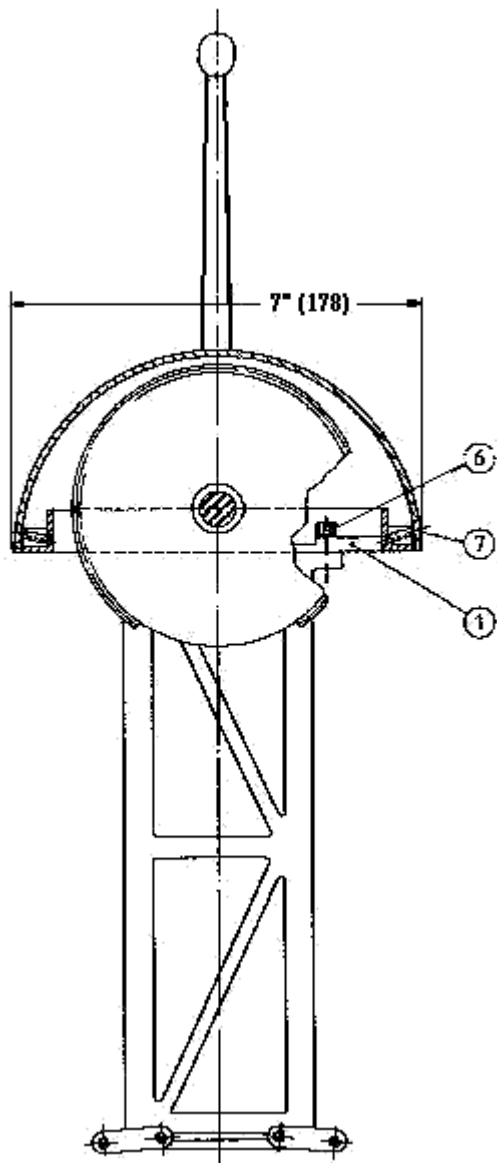

Front View

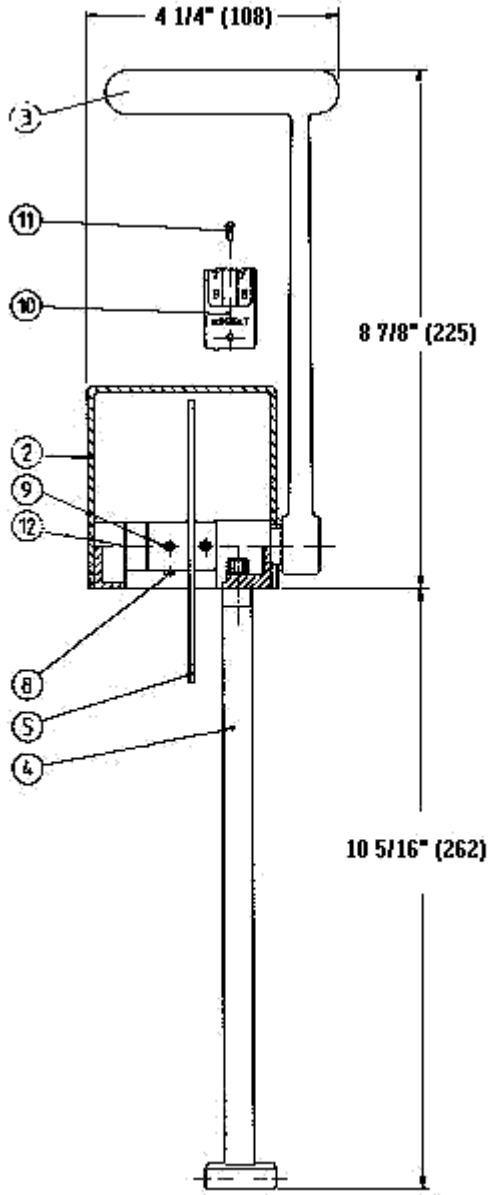

ALL DIMENSIONS IN INCHES (MM)

ITEM	QUANTITY	PART NUMBER	DESCRIPTION
1	1	2006-0001	Frame
2	1	2006-0002	Dome
3	*1	2090-0019	Handle (T-Bar)
3	*1	2090-0020	Handle (Curved)
4	1	2093-0001	Support
5	1	2093-0002	Sprocket
6	2	1002-1008	Hex. Socket Hd. Cap Screw
7	2	1005-0808	Oval Head M. Screw
8	1	1016-0804	Hex. Socket Set Screw
9	2	1024-0816	Spring Pin
10	1	2050-0026	Label
11	2	1032-0304	Rivet
12	1	2090-0021	Spacer

* Quantity may vary.

2093 "Cut-Out" Dimensions

